

LS-7 Series Side-Mounted Level Switches (Metallic)

Instruction Bulletin No.160375

Specifications . . .

Mounting Type	Materials			Min. Liquid Sp.Gr.	Operating Temperature	Operating Pressure, Max.	Switch SPST	Lead Wire Gauge	Part Number
	Stem and Mounting	Float	Lead Wire Jacket						
6	Aluminum	Nylon	PVC	.65	-40°F to +250°F (-40°C to +121.1°C)	100 PSI @ 70°F	10 VA		155660
		Polysulfone		.75	-40°F to +225°F (-40°C to +107.2°C)	150 PSI @ 70°F			155680
8	Zinc	Nylon	TPE†	.65	-40°F to +250°F (-40°C to +121.1°C)	100 PSI @ 70°F	20 VA	#22 AWG	160950
		Polypropylene*		.55	-40°F to +225°F (-40°C to +107.2°C)	150 PSI @ 70°F			162795
9	316 Stainless Steel	316 SS	TPE†	.80	-40°F to +300°F (-40°C to +148.9°C)	300 PSI @ 70°F	20 VA	#22 AWG	164870
		Nylon		.65	-40°F to +250°F (-40°C to +121.1°C)	100 PSI @ 70°F			164850
		Polypropylene*		.55	-40°F to +225°F (-40°C to +107.2°C)	100 PSI @ 70°F			164860
11	316 SS	316 SS	TFE	.80	-40°F to +300°F (-40°C to +148.9°C)	300 PSI @ 70°F			179445

† Thermoplastic Elastomer Zip Cord

* The hydrolytically stable, glass-reinforced polypropylene is UL-recognized to UL 746B at a relative temperature index of 65 degrees C

This product is suitable for Class I and Class II applications only, per the requirements of standard EN60730 and any additional specific requirements for a particular application or medium being sensed. Class I compliance of metal bodied units requires a ground connection between the metal body and the earthing system of the installation. Class I compliance of plastic bodied units in contact with a conductive medium requires that the medium be effectively earthed so as to provide an earthed barrier between the unit and accessible areas. For Class III compliance, a supply at safety extra-low voltage (SELV) must be provided. Please consult the Factory for compliance information on specific part numbers.



Typical Wiring Diagram

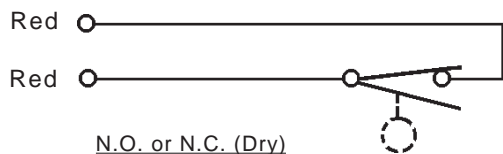

* Switch Ratings - Maximum Resistive Load

VA	Volts	Amps AC	Amps DC
10 General Use	0-50	.2	.13
	120	.08	N.A.
	100	N.A.	.1
20 Pilot Duty	0-30	.4	.3
	120	.17	.13
	240	.08	.06

- Installation -

Mounting Type 6

Install from outside of the tank through 7/8" - 14 boss. Tighten jam nut carefully to seat seal and washer. (See detail below) Do not overtighten.

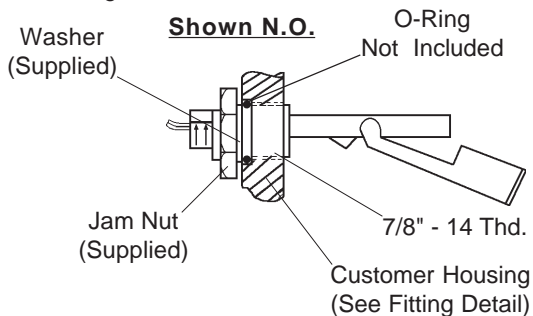

Mounting Types 8 and 9

Install with float positioned as shown for the required switch operation. Be sure that markings on wrench flats show the arrow head in vertical position: At the top for N.O. operation and at the bottom for N.C. operation.

Mounting Types 11

Install with float positioned as shown for the required switch operation. Assemble gasket (by user) on 5/8"-11 threaded mounting and install unit through clear hole in tank side, from inside of tank. Lock in place with Hex nut (supplied).

Fitting Detail . . .

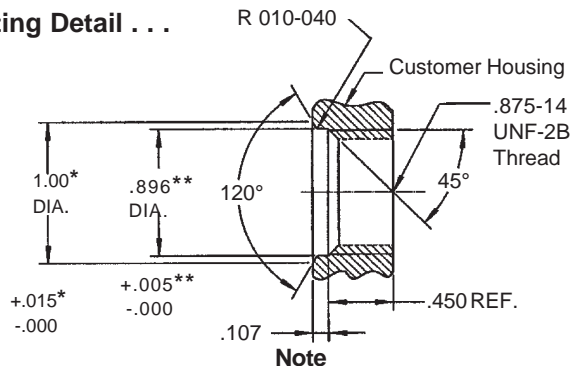

Note: Mating housing requirements for #3-910 O-ring (P/N 11121)

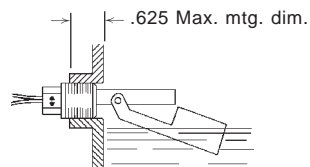

Unit Shown Installed "Float Down" for N.O. (Dry) Operation

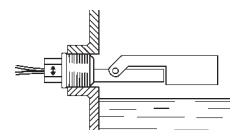

Unit Shown Installed "Float Up" for N.C. (Dry) Operation

Dimensional Data - Type 6
P/N 155660 and 155680

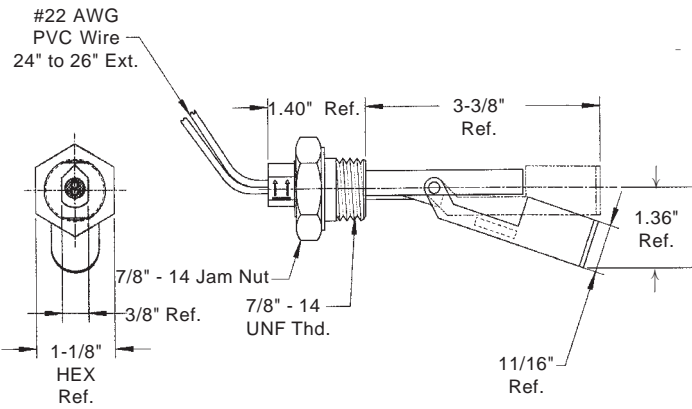

Dimensional Data - Type 8
P/N 160950 and 162795

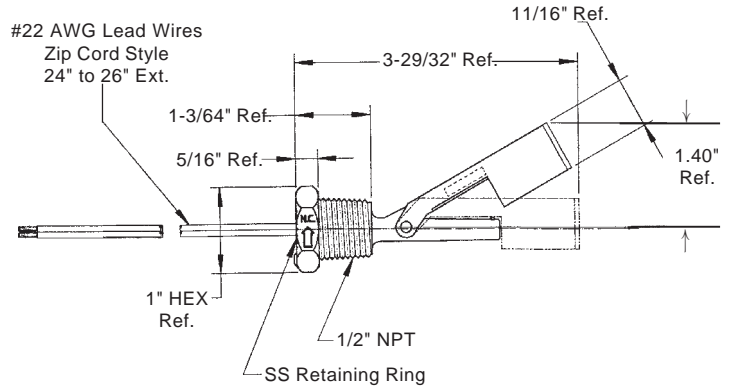

Dimensional Data - Type 9
P/N 164850, 164860 and 164870

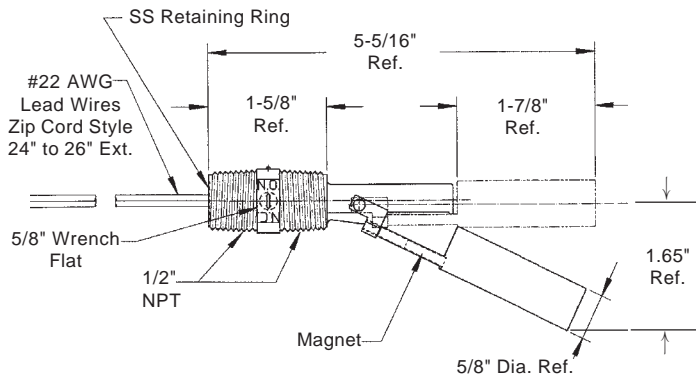

Dimensional Data - Type 11
P/N 179445

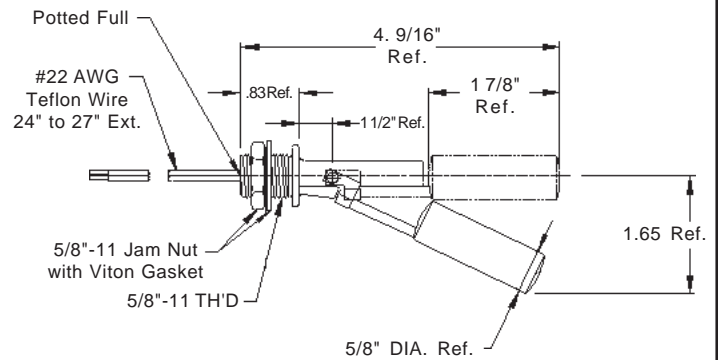

Switch Operation

Depending on the mounting position, the float on these switches can either rise or lower with the liquid level. By rotating the switch 180°, the switch operation can be Normally Open or Normally Closed. Arrows on exterior of mounting indicate N.O. when pointing up.

Maintenance

Normally, no maintenance of any kind is required. When excessive contamination is present in the liquid, an occasional wipe-down cleaning is all that is needed.

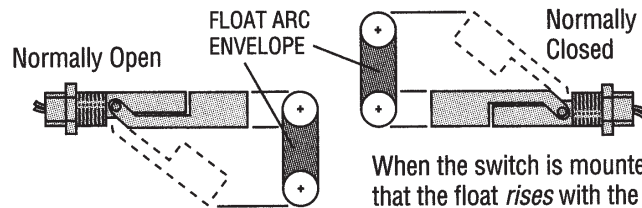

When the switch is mounted so that the float *lowers* with the liquid level, the switch is N.O.

When the switch is mounted so that the float *rises* with the liquid level, the switch is N.C.

European Pressure Directive Addendum

The product is designed and manufactured in accordance with Sound Engineering Practice as defined by the Pressure Equipment Directive 97/23/EC. This product must not be used as a "safety accessory" as defined by the Pressure Equipment Directive, Article 1, Paragraph 2.1.3. The presence of a CE Mark on the unit does not relate to the Pressure Equipment Directive.

Important Points!

Product must be maintained and installed in strict accordance with the National Electrical Code and GEMS technical brochure and instruction bulletin. Failure to observe this warning could result in serious injuries or damages.

An appropriate explosion-proof enclosure or intrinsically safe interface device must be used for hazardous area applications involving such things as (but not limited to) ignitable mixtures, combustible dust and flammable materials.

Pressure and temperature limitations shown on individual catalog pages and drawings for the specified level switches must not be exceeded. These pressures and temperatures take into consideration possible system surge pressures/temperatures and their frequencies.

Selection of materials for compatibility with the media is critical to the life and operation of GEMS level switches. Take care in the proper selection of materials of construction; particu-

larly wetted materials.

Life expectancy of switch contacts varies with applications. Contact GEMS if life cycle testing is required.

Ambient temperature changes do affect switch set points, since the specific gravity of a liquid can vary with temperature.

Level switches have been designed to resist shock and vibration; however, shock and vibration should be minimized.

Liquid media containing particulate and/or debris should be filtered to ensure proper operation of GEMS products.

Electrical entries and mounting points may require liquid/vapor sealing if located in an enclosed tank.

Level switches must not be field repaired.

Physical damage sustained by the product may render it unserviceable.